

EED-023D

Round Leg Dual-Motor Sit-Stand Desk



Born Elegant

Stylish Round Columns and Stable Design
Innovative Control Panel with 2 Colour Options



ROUND LEG DUAL-MOTOR SIT-STAND DESK

EED-023D

Innovative Control Panel

- 2 Memory Settings
- Time Reminder
- CM/INCH Conversion
- User Programmable Height Range
- Adjustable Collision Sensitivity
- Child Safety Lock

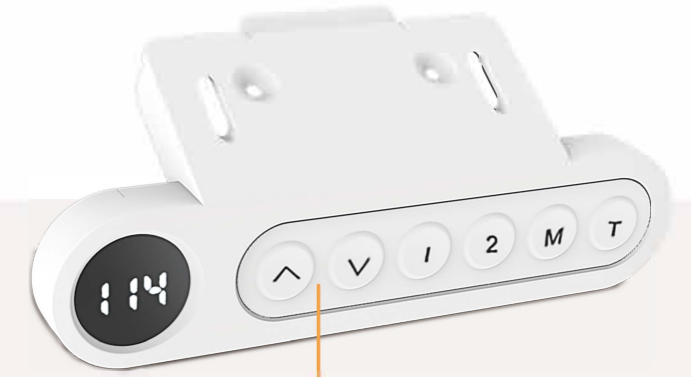

Silicone Buttons
for soft touch and responsive control

Note: Dimensions in the line drawings are mm.

EED-023D With Control Panel

Round Columns 3-Stage

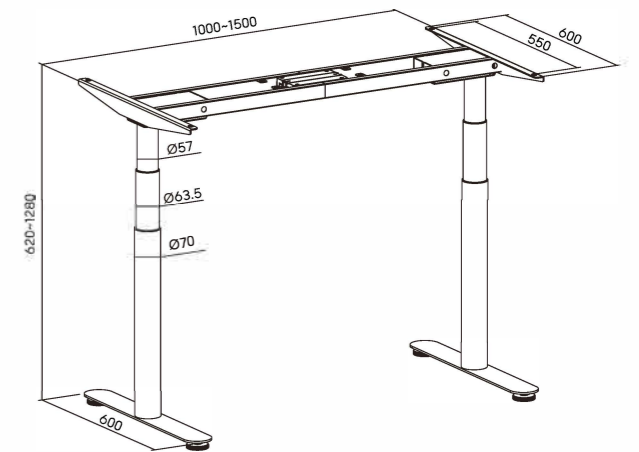

Desk Frame Colours:

Control Panel Colours:

Item No.	EED-023D
Max. Speed	36mm/s
Height Range	620-1280mm
Width Range	1000-1500mm
Weight Capacity	125kg
Control Type	Button Control Panel
Decibel	<50dB
Power Input	100-240V
Desk Frame Colour Options	White
Control Panel Colour Options	White